

Busa Dry Kit



Thank you for purchasing our product!

This kit can be installed in just a couple of hours and soon you will be on your way to adding horse power to your engine safely and effectively.

This kit includes:

- 1- Nitrous bottle rated for 1.2 pounds of nitrous
unless your kit is upgraded to a larger bottle please weight bottle empty before filling
to determine your bottle size
- 1- Nitrous bottle mounting bracket
- 1- Nitrous solenoid
- 1-24 inch hose that is 4an to 4an female hose ends
 - 2- 4an to 1/8 n.p.t. fittings
- 2- Jet holder fittings with nuts and compression ferrules
 - 1- Assorted adjustable funnel jet pack
 - 1- 1/8 tubing push to lock Tee fitting
- 1- Pack of assorted electrical connectors
 - 1- Toggle switch
 - 1- Roll of poly tubing 1/8 diameter

Tools needed:

- Powered Drill
- Drill bit #3 (.2130 decimal inches)
- Tap 1/4 28 thread pitch
- Wire strippers
- Wire crimpers
- 9/16 wrench
- 1/2 wrench
- 7/16 wrench
- 3/8 wrench

First you'll want to mount the nozzle fittings (jet holder) the air box was only removed for the picture purpose.

The nozzle threads are $\frac{1}{4}$ 28 thread pitch and use a #3 drill bit to drill your holes

Air box

these corners would be ideal nozzle placement

before you drill and tap the holes you want to have an idea of the angle you need to drill at, just make sure you place nozzles so that they intersect in an X pattern to maximize the nitrous distribution in the air box. (shown here by the red X)

Also be sure that the placement of the nozzle does not interfere with the fuel tank



USE A #3 DRILL BIT
TO DRILL IN AIR BOX

COMPRESSION NUT AND FERRAL

FUNNEL JET



This is the order in which the nozzle fitting should be installed in the Air box



When locating the solenoid be sure not to mount too close to exhaust pipes
excessive heat can damage the solenoid



Also mount the bottle away from high heat sources
The bottle has a siphon tube attached to the valve that
can be removed to mount bottle inverted

Weight of 1.2lb bottle
Empty: 2.0lbs
Bottle plus Nitrous:
3.2lbs

Weight of 2lb bottle
Empty: 3.5lbs
Bottle plus Nitrous:
5.5lbs

Wiring

MOTORCYCLE DRY KIT WITH HORN ACTIVATION

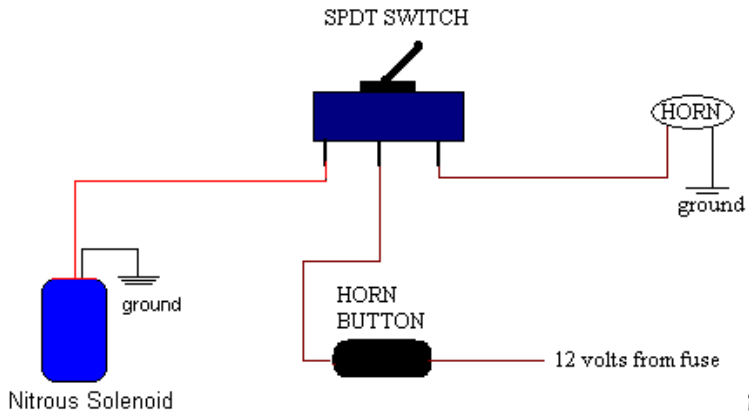

figure 1

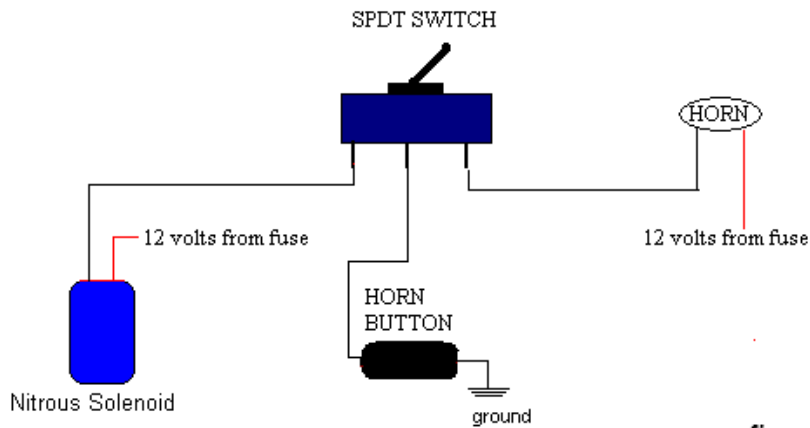

figure 2

Note:

To use your horn button first you need to determine if your button switches to ground or power.

To test find your horn and unplug the wires and connect a test light to ground and touch a terminal if the test light is glowing you found a power wire press your horn button to see if the light turns off if the test light remains on you will need to use figure 2 to proceed to wire the Nitrous kit.

Test horn system with the key in the run position